



# NST-Solar LED



The **NST-Solar LED** is an All-In-One LED solar-powered luminaire designed to provide sufficient illumination in most applications. The robust water and dust proof design makes the luminaire suitable for even the most remote locations across Africa. It has an integrated motion sensor that allows the **NST-Solar LED** to provide 100% light output when motion is detected and 50% light output when it detects no activity, ensuring preservation of the batteries capacity.



## NST-Solar LED

**Applications:** Walkway, Perimeter, Urban Roads, Rural, Security, Parking, Off-Grid Areas & Area Lighting.

**Housing:** Body manufactured from die-cast aluminium and powder coated.

**Solar Module:** Polycrystalline panel.

**LED:** Efficient High Power LED's used with polycarbonate optic lenses.

**Battery:** Lithium battery technology which provides sufficient capacity for up to 2 days when fully charged.

**Motion Sensor:** The luminaire will provide 50% of its light output, and as soon as motion is detected, the light output increases to 100%.

**Mounting:** Powder coated die-cast aluminium bracket.

**Warranty:** 5 years

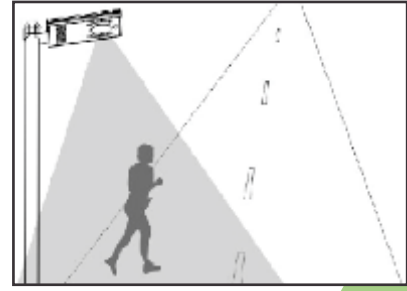

100% LIGHT OUTPUT

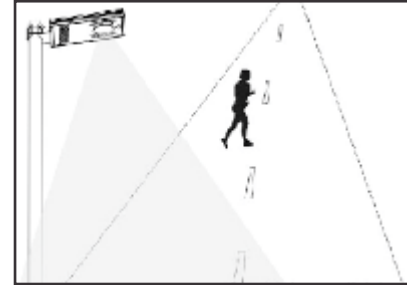

50% LIGHT OUTPUT

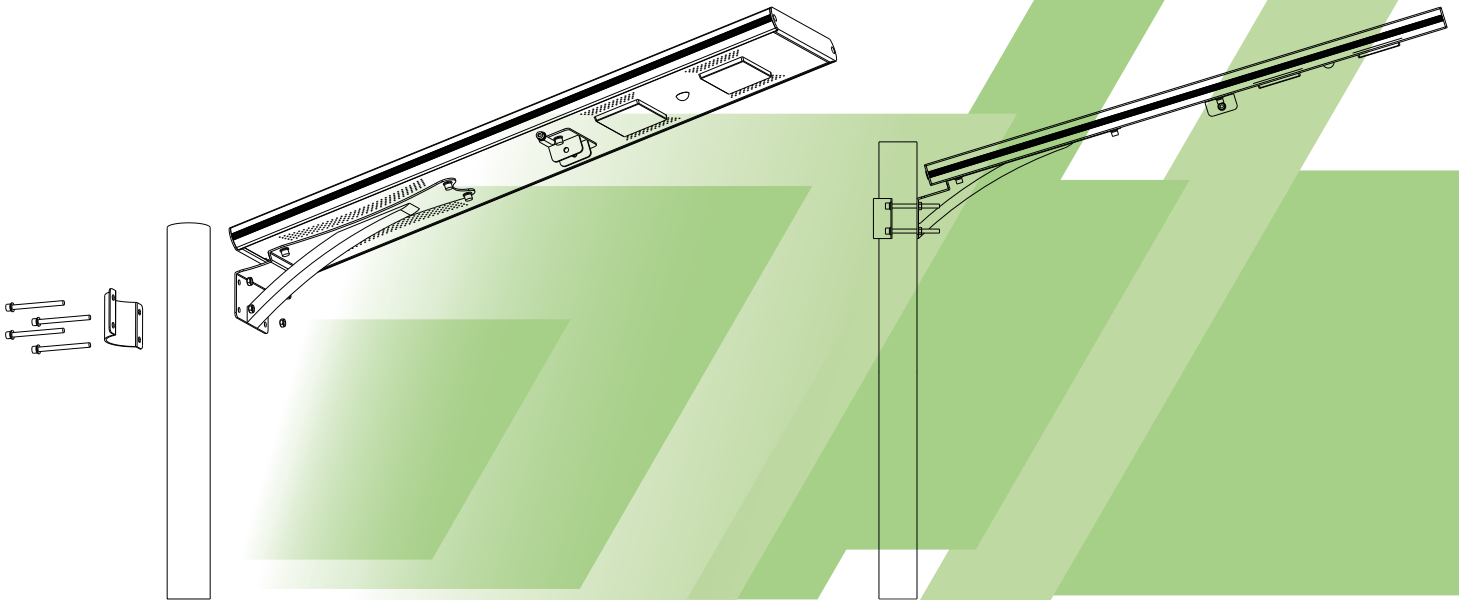

<b>Model Name</b>	NST-Solar LED
<b>LED Rated Wattage(w)</b>	40W
<b>Solar Panel Rated Wattage(w)</b>	60W
<b>Luminous Flux(LM)</b>	5200lm
<b>Luminous Efficiency</b>	130lm/W
<b>Colour Temperature</b>	6500K
<b>Ambient Temperature</b>	-20°C~+60°C
<b>Beam Angle</b>	120°
<b>Ingress Protection Grade</b>	IP65
<b>Installation</b>	Pole or Wall mount
<b>Dimensions</b>	L x W x H
	755x380x50mm
<b>Weight</b>	10kg

Ramika Projects reserves the right to change any specification or design without prior notice.

Tel: 010 443 9149 | Email: [sales@ramika.co.za](mailto:sales@ramika.co.za) | Web: [www.ramika.co.za](http://www.ramika.co.za)



**RAMIKA PROJECTS**